

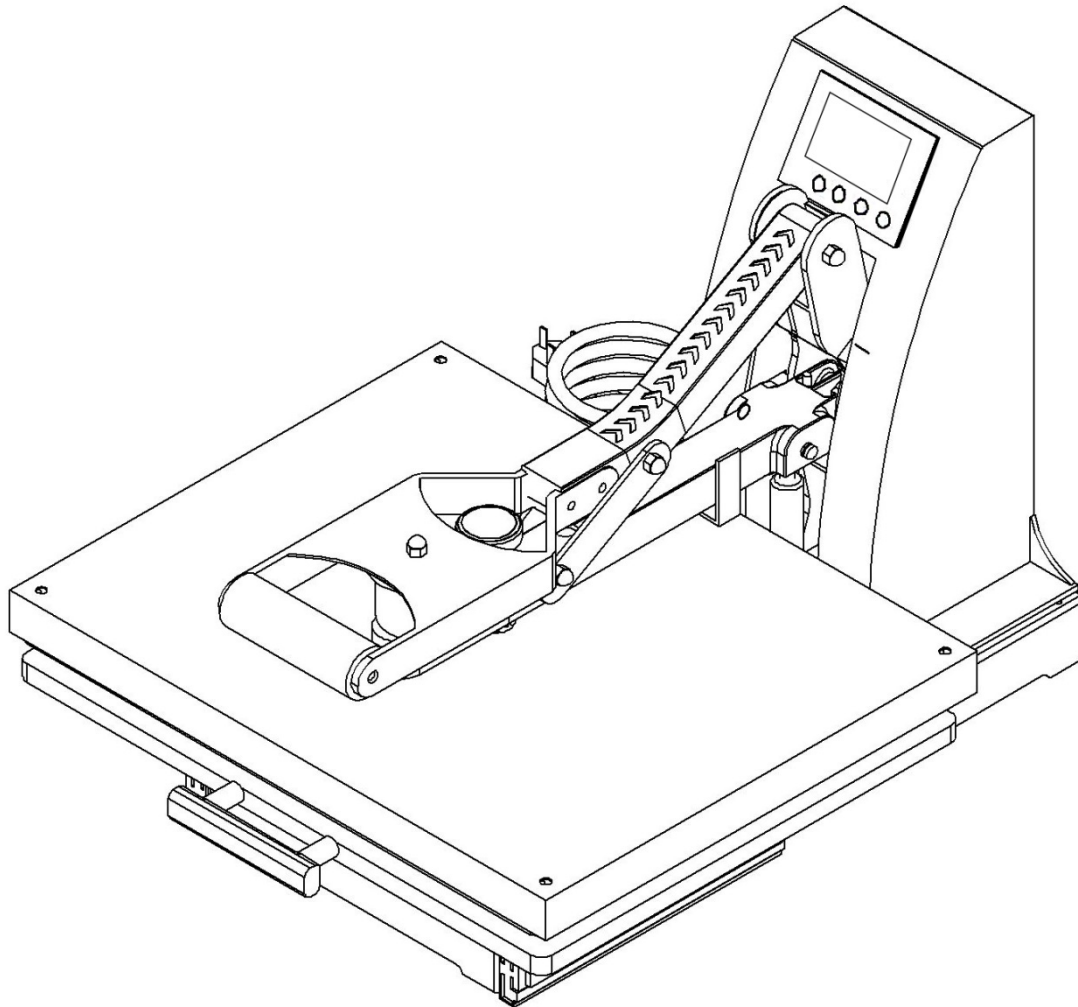

Auto Clam Heat Press Model Nos.: XP7600 & XP7604



CONTENTS.

I.	Assembly Drawing	2
II.	Technical Parameters	2
III.	Operating Process	3
IV.	Maintenance	4-5
V.	Trouble Shooting For Transfer Print Quality	6
VI.	Heat Plate Temperature Measurement	7
VII.	Circuit Diagram	8
	Declaration of Conformity	9

I. Assembly Drawing.

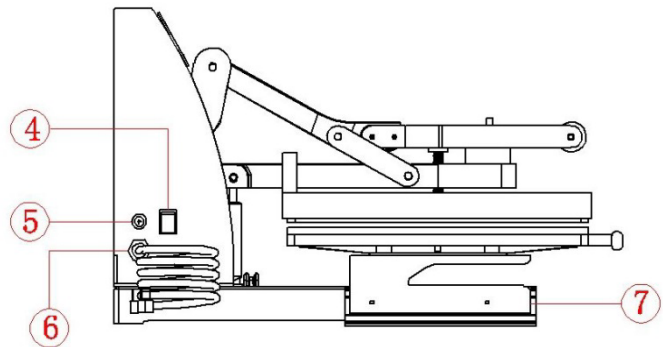
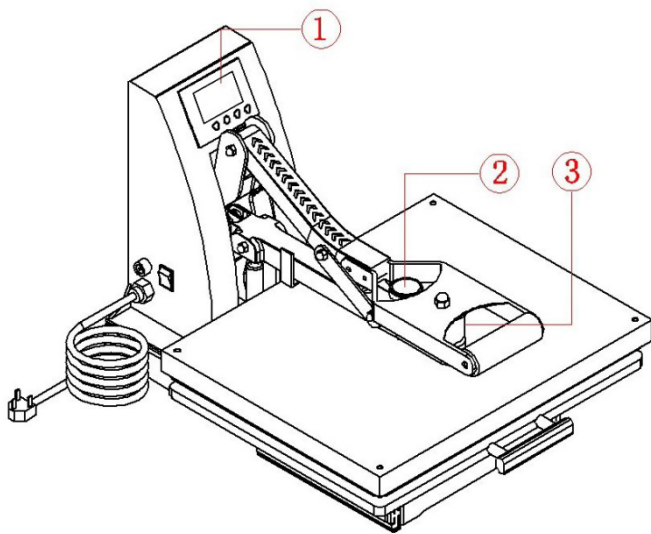

- | | | | |
|-----------------------|-------------------------|------------------|-----------------|
| 1) Digital Controller | 2) Pressure Adjust Knob | 3) Electromagnet | 4) Power Switch |
| 5) Fuse | 6) Power Cord | 7) Machine base | |

II. Technical Parameters.

1. Model No.: XP7600 & XP7604
2. Machine Dimension: 415 x 676 x 620 mm
3. Heat Platen Size: 38 x 38cm & 40 x 50 cm
4. Printable Articles Max Size: 400 x 600 x 20 mm
5. Voltage: 220 V/ 1 Phase; 110 V/ 1 Phase
6. Power: 220 V/ 1.8 kW; 110 V/ 1.2 kW
7. Recommended Settings: 30~280s; 180~200°C
Time Range: 0~999s
Maximum Temp: 225°C
8. Packing Size: 71 x 50 x 54 cm/ 76 x 62 x 58 cm
9. Gross Weight: 25 Kg/ 39 Kg

III. Operating Process.

Note: The head must always be in the up position before the controller is set

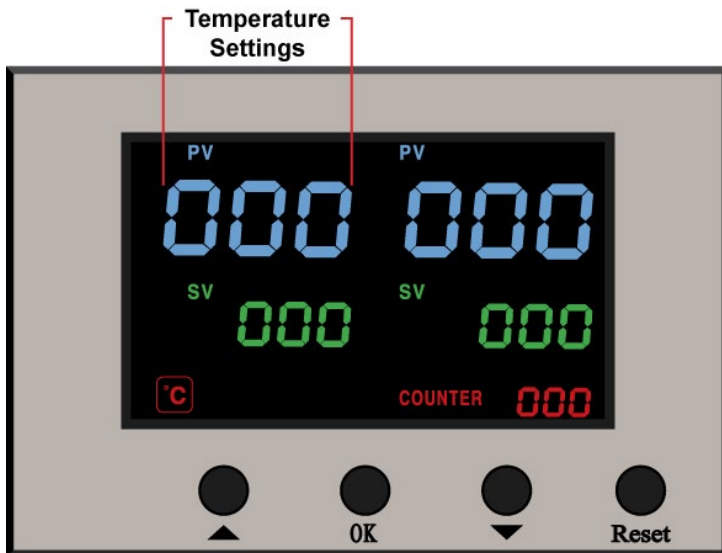

Setting Temperature:

1. Switch on machine.
2. Press the 'OK' button to enter the temperature setting mode (the '°C' light will flash).
3. Using the '▼' or '▲' buttons select between '°C' or '°F'.
4. Press the 'OK' button twice to enter the temperature setting mode (the temperature settings digits and 'SV' will flash).
5. Use the '▼' or '▲' buttons to select the temperature required for the transfer material being used.
6. Press the 'OK' button to turn the 'SV' light and temperature settings digits off.

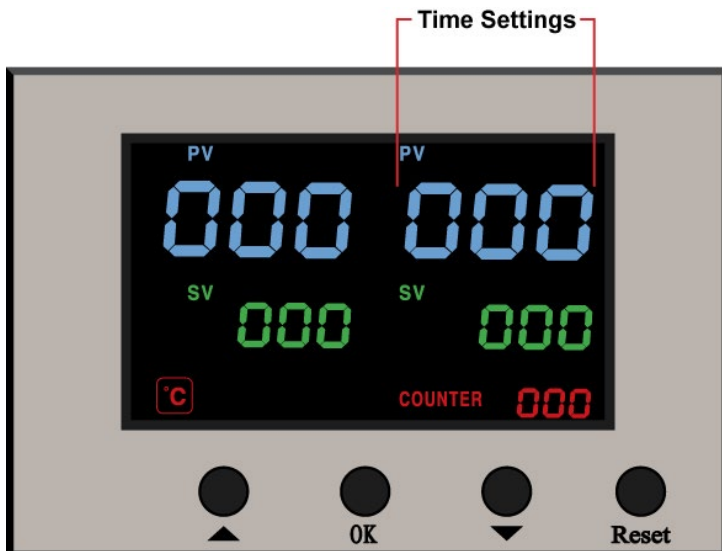

Setting Time:

1. Press the 'OK' button three times to enter the time setting mode (the 'SV' and time settings lights will flash).
2. Use the '▼' or '▲' buttons to select the time required for the transfer material being used.
3. Press the 'OK' button to turn the 'SV' and time settings lights off.
4. The digital display will now show the rising temperature until the set heat is achieved. At this point a buzzer will sound to indicate that the machine has reached the set operating temperature and is ready to use.
5. **To reset the counter to zero press and hold 'Reset' button for 5 seconds.**

IV. Maintenance.

1. The machine will not work after you turn on the power.

- 1). Check the plug is connected well or that it is not broken.
- 2). Check the power switch or digital controller is not broken.
- 3). Check the fuse is not blown.
- 4). Indicating light is on, but no display on screen, check the 5 cable of Railway transformer. If it is loose, this indicates that the problem is poor connection. If it is securely connected, it indicates that the Transformer is faulty.

2. The display screen is working well, but the heat platen temperature does not rise.

- 1). Check whether the thermocouple of the heat platen is secure. If the thermocouple is loose, the display will show 255°C and the machine will keep beeping.
- 2). Check if the indicating light of the solid-state relay is on. If not, check if the relay or digital controller is broken.
- 3). If you have already replaced the solid-state relay for a new one but the heat platen will still not heat up, then check to see if the heat platen is faulty or the heat platen's power cable is loose, you may need a new heat platen.

3. The heat platen works well, but suddenly the display screen shows 255°C.

- 1). Check whether the thermocouple is secure.
- 2). If the thermocouple is firmly attached but the controller still shows 255°C, then it is faulty.

4. The machine is heating between 0~180°C, but the display number jumps to above 200°C or 300°C suddenly, or the numbers on the display jump irregularly.

- 1). Check whether the thermocouple of the heat platen is firmly attached.
- 2). If the thermocouple is OK, It shows that the program of the digital controller is broken. You will need to replace it for a new controller.

5. The temperature is out of control: Set to 180°C, but the actual temperature is above 200°C.

- 1). This indicates that the solid-state relay is broken/ out-of-control; You will need to replace the relay.
- 2). Alternatively, the digital controller could be faulty with an open circuit providing constant power; You will need to replace the controller.

6. The setting temp and time becomes abnormal after you have replaced the heat platen.

- 1). Please reset the temp and time according to this operators' manual.

7. Maintenance.

- 1). In order to prolong the machine's service life, you should regularly lubricate all mechanical joints with light machine oil.
- 2). Care should be taken to protect the heat platen whenever the machine is not in use. This will prolong the life of the platen and help to keep the image quality of your work high.
- 3). The machine should be stored in a dry place.
- 4). If you are not able to solve your problem, please contact heatpressesdirect.com for technical support.

8. The following checks should be carried out at regular intervals by a qualified and competent person:-

- Electrical connections
- Mechanical moving parts

V. Trouble shooting for transfer print quality.

1. If the print colours are pale: the temperature is too low / the pressure is not correct / or the transfer has not been pressed for long enough.
2. If the print colour is too brown or the transfer paper is almost burnt: reduce the setting temperature.
3. If the print is blurring: too much transfer time causes proliferation of the ink.
4. If print colour is different/ partial transfer effect is not good enough: the pressure is not enough / or the transfer has not been pressed for long enough / or poor quality transfer paper.
5. If transfer paper sticks to the object after transfer: the temperature is set too high/ or poor quality printing ink.

VI. Heat Plate Temperature Measurement

Testing of the Heat Plate for temperature consistency or fault condition should only be undertaken after consulting a qualified engineer, and then only using a wired Digital Thermometer (***please see note below**).



***Please Note:**

The **Digital Thermometer with external probe** is suitable for surface, air and immersion/penetration measurement, which is required for all Heat Presses Diect heat presses.

Laser Thermometers only measure air surfaces which can be misleading due to currents of hot air floating on the surface of the heat plate.

VII. Circuit Diagram.

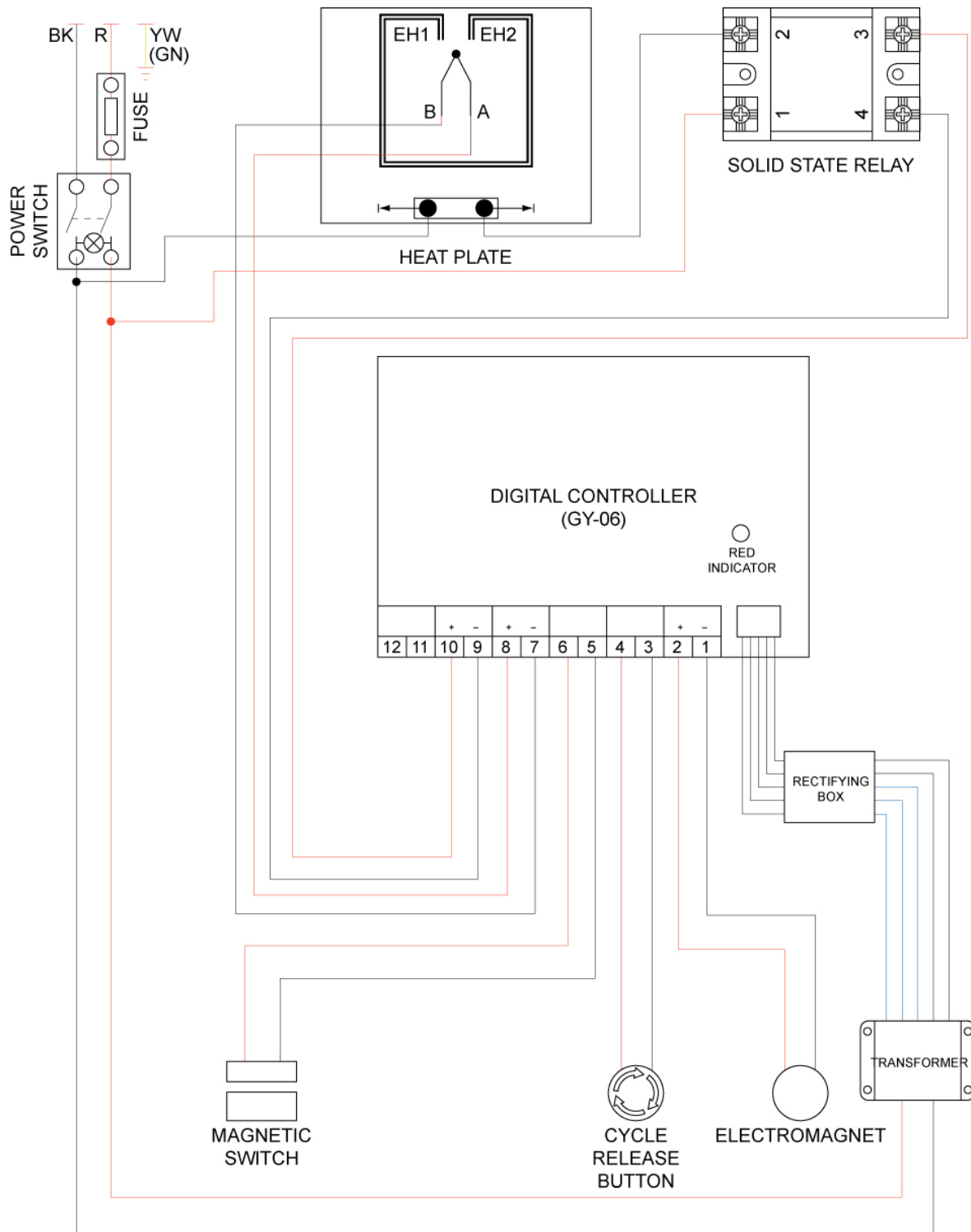

Key:

KO: Power Switch

EH1 EH2: Heating Pipe

T: Transformer

K2: Limit Switch

SJ: Thermostat

R1: Relay

FU: Fuse(16A/25V)



C: Magnet

MD: Magnet Driver



Charterhouse Holdings PLC

DECLARATION OF CONFORMITY

Application of Council Directives:	European Low Voltage Directive (LVD), European Machinery Directive (MD), Electro Magnetic Conformity (EMC)
Standards to which Conformity is Declared:	(LVD): <u>EN 60204-1:2018</u> (MD): <u>EN ISO 12100:2010 2006/42/EC Annex1</u> (EMC): <u>EN 61000-6-2:2019</u>
Manufacturer's Name:	Charterhouse Holdings PLC
Manufacturer's Address:	Oakridge Park, Trent Lane, Castle Donington, Derby DE74 2PY United Kingdom
Type of Equipment:	Auto Clam Heat Press
Standards Compliance:	 
Model Number:	<u>XP7600</u>
Serial Number:
Year of Manufacture:

I, the undersigned, hereby declare that the equipment specified above conforms to the above directives and standards.

Place: Castle Donington, United Kingdom

Signature: M.S. Carter

Date: 15th June 2023



Full Name: Miles Carter

Position: Chief Executive



Charterhouse Holdings PLC

DECLARATION OF CONFORMITY

Application of Council Directives:	European Low Voltage Directive (LVD), European Machinery Directive (MD), Electro Magnetic Conformity (EMC)
Standards to which Conformity is Declared:	(LVD): <u>EN 60204-1:2018</u> (MD): <u>EN ISO 12100:2010 2006/42/EC Annex1</u> (EMC): <u>EN 61000-6-2:2019</u>
Manufacturer's Name:	Charterhouse Holdings PLC
Manufacturer's Address:	Oakridge Park, Trent Lane, Castle Donington, Derby DE74 2PY United Kingdom
Type of Equipment:	Auto Clam Heat Press
Standards Compliance:	 
Model Number:	<u>XP7604</u>
Serial Number:
Year of Manufacture:

I, the undersigned, hereby declare that the equipment specified above conforms to the above directives and standards.

Place: Castle Donington, United Kingdom

Signature: M.S. Carter

Date: 15th June 2023

Full Name: Miles Carter

Position: Chief Executive